



INSTALLATION & TECHNICAL OPERATIONS GUIDE





INSTALLATION CHECK IN / CHECK OUT

Email completed form and required pictures to: drew.keller@vividairmovement.com

Company: _____
Address: _____
City/State/Zip: _____ Contact Name: _____
Email: _____ Phone: _____

INSTALLATION CHECK IN

Installation crew supervisor and facility manager are to complete checklist prior to entering the jobsite or unloading materials.

- Contractor and customer have reviewed the scope of work/layout including: fan placement, controller placement, and power supply panel(s) to be used.
- Contractor and customer have reviewed the fan installation manual for the type of fan mount at each location.
- Contractor and customer have reviewed the installation schedule and any site specific safety rules and regulations (i.e., specific requirements, gear, certifications, lock out/tag out, prohibited areas, secure areas, areas to avoid, special machinery, dangerous conditions or areas and how to detour such places if needed):

Additional Comments: _____

Customer Signature: _____	Contractor Signature: _____
Printed Name: _____	Printed Name: _____
Date: _____	Date: _____

INSTALLATION CHECK OUT

Installation crew supervisor and facility manager are to complete checklist after completing installation.

- Fan and controller placement agrees with the check in (above), scope of work and layout.
- Contractor has reviewed with the customer the breaker location for all fans and the customer understands the lock out/tag out (LOTO) procedure on all fan controllers.
- No safety incidents were reported by or on the contractor during the fan installation.
- All fans are running and the customer has been trained on operation in both directions. The fan operation section of the manual has been reviewed.
- The customer understands the warranty for each fan and the warranty information in the manual has been reviewed.
- The customer has been given a copy of the installation manual for all styles of VividAir fans installed as part of this project.
- The customer is comfortable with fan operation including starting/stopping, speed adjustment, reversing direction, and power disconnect with LOTO.
- The contractor has taken pictures of all fans individually clearing showing the full fan in the ceiling (required to activate the warranty).
- The contractor has taken pictures of all fans clearly showing the routing and connection of both safety cables (required to activate the warranty).
- The contractor has taken pictures of all fan controllers once mounted in their final locations (required to activate the warranty).

Customer Signature: _____	Contractor Signature: _____
Printed Name: _____	Printed Name: _____
Date: _____	Date: _____

What to expect in your TAZ fan shipment:

TAZ Fan Assembly

(1) ABB Control
(Installation Manual Inside
the Controller Box)

(4) Louver Mounting
Brackets

(6) Louvers

(1) Hardware Box
(2) Truss Mount Kits
(Inside Controller Box)



Table of Contents

1. The 7ft TAZ Fan.....4
 Introduction.....4

2. Receiving Your Fan.....5

Mechanical Installation Procedure

3. Initial Fan Assembly Inspection - Before You Raise The Fan.....5
 Fan Location Rules.....5

3.1 Optional Methods To Complete Your TAZ Fan Installation.....5

4. Inspect And Layout Your TAZ Fan.....6

5. Prepare TAZ For Hanging.....6-7

6. Lift TAZ Into Its Final Position And Secure All Four Chains.....7-8

7. Install Louver Brackets.....9

8. Attaching The Louvers.....10

Electrical Installation Procedure

Electric Installation.....11
 Safety Precautions.....11
 Required pictures for proper installation.....11

9. Wiring Requirements.....12
 Block Diagram.....12
 Wire Requirements & Rules.....12

10. Cable Length Table.....13

11. Power Requirements.....13

12. Wire Location.....14

13. ESFR Fire Suppression System Connections.....15

14. Wire Connections (Motor) Motor.....16

15. Quick Operations Instructions For The VFD.....17

16. Recommended Maintenance Schedule.....18-19

17. 7 FT TAZ Fan Clearance Requirements.....20

18. Recommended Maintenance Checklist.....21

Warranty Information.....22-25

Follow the Factory Mutual Insurance Company (FM Global) standards, Heating equipment manufacturer's guideline and safety standards such as those published by the National Fire Protection Association (NFPA), and the American Society for Heating, Refrigeration and Air Conditioning Engineers (ASHRAE), and local code authorities.

1. The VividAir 7ft TAZ Fan

Congratulations on purchasing one of the most unique fans in the HLVS industry! The 7ft TAZ Fan from VividAir has several performance advantages over every Large Diameter Fan in the market. Let's take a look:

- You are not out of reach at 150 FT! This fan that can help your people 150 FT away.
- 2 Options for airflow distribution.
 1. Balanced - Even air distribution in both directions from the fan location.
 2. Single Direction - All louvers pointing the same way for maximum airflow.
- Maximum cooling breeze. No HVLS fan creates a greater breeze than the 7ft TAZ Fan from VividAir!
- Winter heat savings. Pull the heat down and reduce the strain on costly HVAC systems.
- Summer cooling savings. VividAir fans work great with your HVAC system. We reduce the operating load increasing efficiency and improving your work environment.
- VividAir can potentially eliminate floor sweating while inhibiting rust and mold growth.

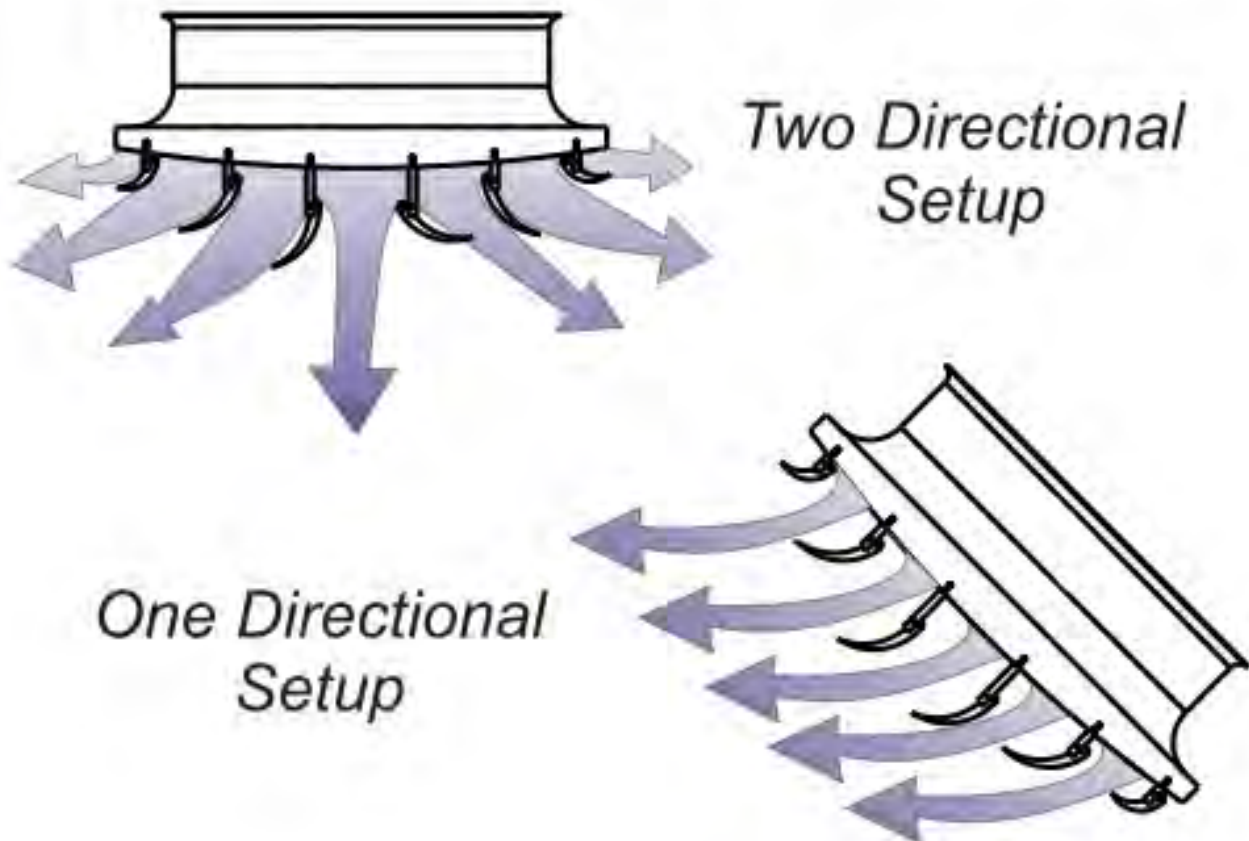

2. Receiving Your VividAir 7 FT TAZ Fan

- You will receive one crate including:
 1. (1) Fan Assembly
 2. (6) Louvers
 3. (4) Louver Mounting Brackets
 4. (1) ABB VFD Control
 5. (1) Hardware Box
 6. (2) Truss Mount Kits



NOTE: Optional equipment, specials or customs may ship separately from the fan crate.

MECHANICAL INSTALLATION PROCEDURE

3. Initial Fan Assembly Inspection (Before You Raise The Fan)



- Inspect the belts, sheaves, motor, blades, housing, louver brackets, louvers, control, and hardware pack.
- Remove all devices designed to prevent the fan from turning during shipment.
 - Fan blades will turn freely once all restraints have been removed. Handle with care.

Fan Location Rules:

1. 6 FT of clearance must be maintained from the top of the fan to the roof deck.
2. Lowest point of the fan assembly must be higher than 7ft from the floor or 1 FT above any vehicle or equipment that moves within the facility.
3. Be sure fan installation adheres to local codes.
4. Keep all TAZ fans at least 20ft from any exhaust fan or port and any heating units.

3.1 Optional Methods To Complete Your TAZ Fan Installation

Option #1 - Forklift Method

Once the fan is prepped for hanging:

- a. Install all (4) hanging chains with quick links ready to support the fan.
- b. Lay the fan flat (skid optional).
- c. Use fork extensions and raise the fan into place.
- d. Secure TAZ to all (4) chains.

Option #2 - Scissor Lift Method

Once the fan is prepped for hanging:

- a. Install all (4) hanging chains with quick links ready to support the fan.
- b. Lay the fan flat (skid optional).
- c. Use fork extensions and raise the fan into place on the scissor lift.
- d. Raise TAZ with the scissor lift and secure all (4) chains.

Complete the TAZ installation using the following pages of this manual.

4. Inspect And Layout Your TAZ Fan

- Remove all components from the shipping skid and layout in the work area.
- Inspect all components for damage prior to assembly.
- Be sure to align your TAZ fan so the Louver Bracket attachment holes in the frame align with the direction you need TAZ to operate.

5. Prepare TAZ For Hanging

- Secure the (4) hanging chains in place.

NOTE: Z-Purlin applications require the Z-Tech™ Fan Z Purlin Kits to support all four fan anchor points. Contact the factory for additional information.

To the right is a picture of the final assembly of the truss mount anchor system.

- (8) square washers are supplied.



Contractor Supplied Hardware:

- (4) 1/2" forged galvanized steel eyebolts minimum WLL of 1500 lbs
 - length determined by application - 3 1/4" shown
- (8) 1/2" Grade 8 flat washers
- (4) 1/2" Grade 8 nylock nuts
- (4) 10' lengths of 1/4" chain
- (8) 3/8" quick links

Tighten hardware to 40 ft lbs (54.2 N·m).

- Locate the 4 chain anchor points.
- Run the forged eyebolt up through the truss and secure in place.
- Chain and Quick Links are contractor supplied.
- VividAir requires 1/4" chain minimum for all (4) suspension locations with 3/8" quick links.

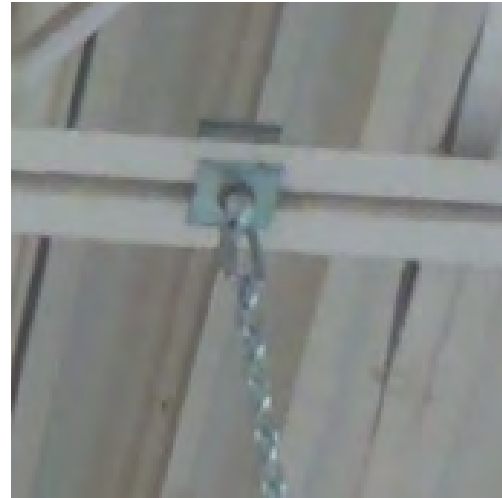

1/4" x 10'
G30 PROOF COIL
NO HOOKS
ELECTRO GALVANIZED



Z-Purlin ceilings require the VividAir Z-Purlin Kit for each of the (4) anchor points. Do NOT hang the TAZ fan from individual purlins.

6fiLift TAZ Into Its Final Position And Secure All Four Chains

- When ready to lift the fan into place remove the (2) shipping braces and lay the fan either on a long skid or on the fork extensions of the forklift.
- Carefully raise the fan onto the scissor lift or into place with the forklift.

- Complete the installation of all (4) suspension points.
- Secure to the eyebolts on the fan with 3/8" quick links.

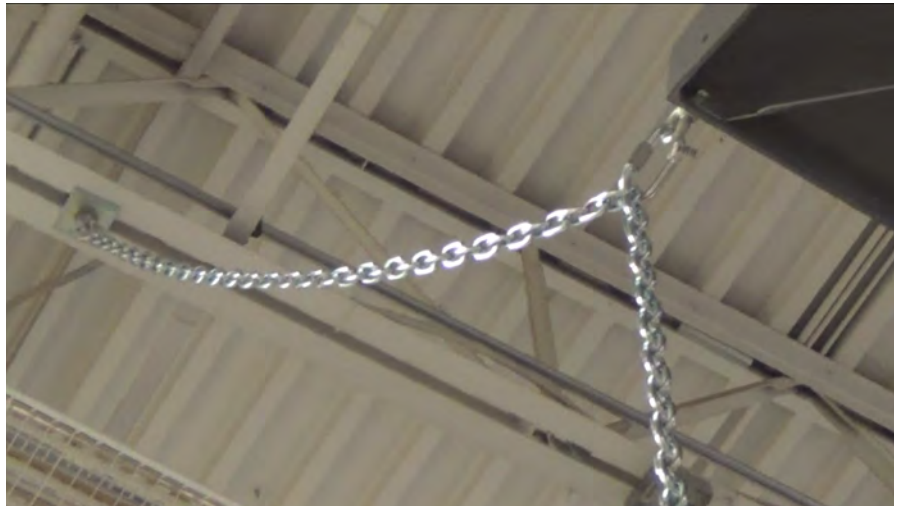

- Slowly lower TAZ so the weight is gradually taken by the chains. The fan may swing as weight is transferred. Support the fan manually to reduce the potential swing to prevent possible damage to the fan.
- To level TAZ we've found it best to square the fan to the room first, then level it by adjusting chain length by counting links. Once TAZ is square simply adjust both chains on either side of the fan to level.

Optional cable mount:

Minimum 7x19x1/8" steel aircraft cable

- Measure and locate the four fan anchor points. Chain or steel cables must have a 10-45 degree angle from the center point of the fan.
- Measure, locate, and secure all four fan anchor points.
- Anchor the chain or steel cable to the eyebolts and secure with (2) cable clamps at each end.
- Fasten the chain or steel cable to the four corners of the fan. Verify fan level before proceeding.

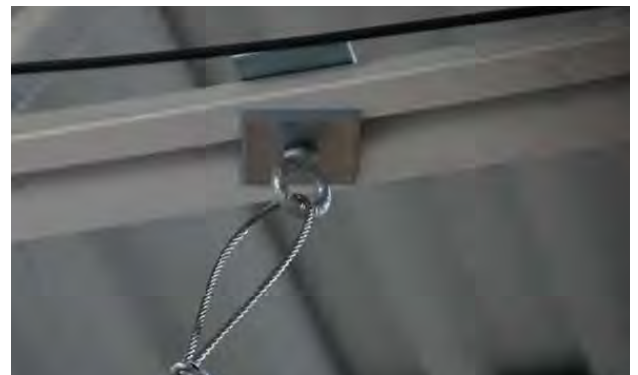

If using steel cable be sure to rout the cable through the cable clamp properly. Pass the cable through the clamp, then through the fan anchor point, then back through the clamp on top of itself.

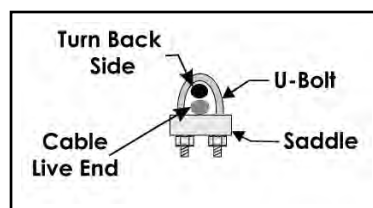

Tighten cable clamp hardware to 4.5 ft-lbs (6.1 N-m).

7fi Install Louver Brackets

- Attach the Louver Brackets with the hardware provided. The brackets **MUST** mount on the outside of the fan body!
- Wrench tighten hardware 10 ft lbs (13.6 N.m). Please note drawings below showing the optional orientation.

Number	Quantity	Part #	Description
1	12	HC1631	M8 Lock Nut
2	12	HC1639	M8 X 30mm Bolt
3	24	HC1342	M8 X 25mm Washer



NOTE Reverse the Louvers as necessary to acheive the desired coverage. We have found the best practice is to NOT install the Louvers until the fan is hanging in it's final location. Pictures below are for reference only to show optional louver direction.

Single Direction

Dual Direction

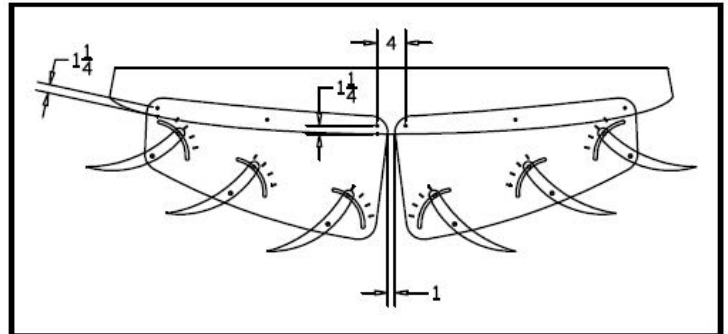
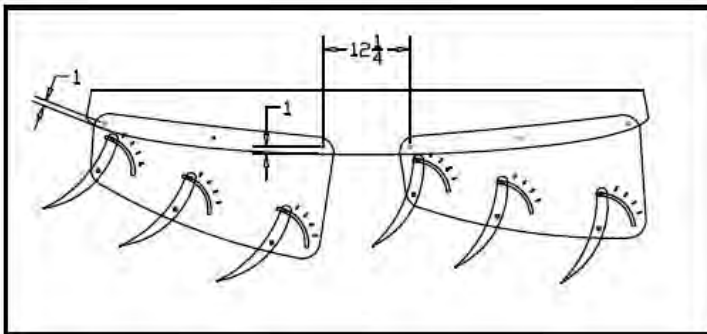

8. Attaching the Louvers

Number	Quantity	Part #	Description
1	24	HC1165	M8 X 40mm Bolt
2	24	HC1342	M8 X 25mm Washer

- Install the louvers in the correct orientation for the application.



- Manually tighten the hardware until all six louvers have been installed. If you tighten the hardware as you go it makes the installation more difficult.



- Wrench tighten all louver hardware to no more than 10 ft lbs (13.6 N·m).
- Adjust louver angle as you tighten so they are in their final position.



ELECTRICAL INSTALLATION & OPERATION MANUAL

All installation wiring must confirm to your National Electrical Code and local guides. While we believe that using VividAir controls and following our instructions will result in an installation that meets those requirements, we cannot guarantee it. Code compliance is ultimately the installer's and/or user's responsibility.

Subject to change without notification.

Safety Precautions

- All installations must be installed by a qualified person.
- Do not work on live equipment. Use lock out/tag out procedures.

CRITICALLY IMPORTANT!!

Upon completion of the installation you **MUST** send the completed VividAir Check In/Check Out form and take 2 pictures of each TAZ fan:

- 1) The overall fan installation.
- 2) Close-Up clearly showing the chain or cable anchor point to the ceiling OR
- 3) Clear view of the wall, column, or floor mount bracket and anchors used.

Please send these pictures to drew.keller@vividairmovement.com

9. Wire Requirements

- VividAir recommends you use 12 ga stranded wire for VividAir installations.
- Size of input and output wires may go up based on length and current draw of VFD and motor.
- See Power Requirements for current draw of VFD and motor.

VFD = Variable Frequency Drive

A separate insulated ground must be provided to each VFD from the electrical panel.

Motor is rated with an Insulation Class F;
Ensure proper wiring is used as per current electrical codes.

Wet/Agricultural-PVC Conduit
Dry (Industrial/Commercial) – EMT Conduit
-3 Phase = (3) 12g Wires + Insulated Ground

Wet/Agricultural-PVC Conduit
3 Phase = shielded cable, inverter-rated,
(3) 12g wires + insulated ground
Dry Industrial/Commercial –EMT Conduit
3 Phase = 3 12g Wires + Insulated Ground

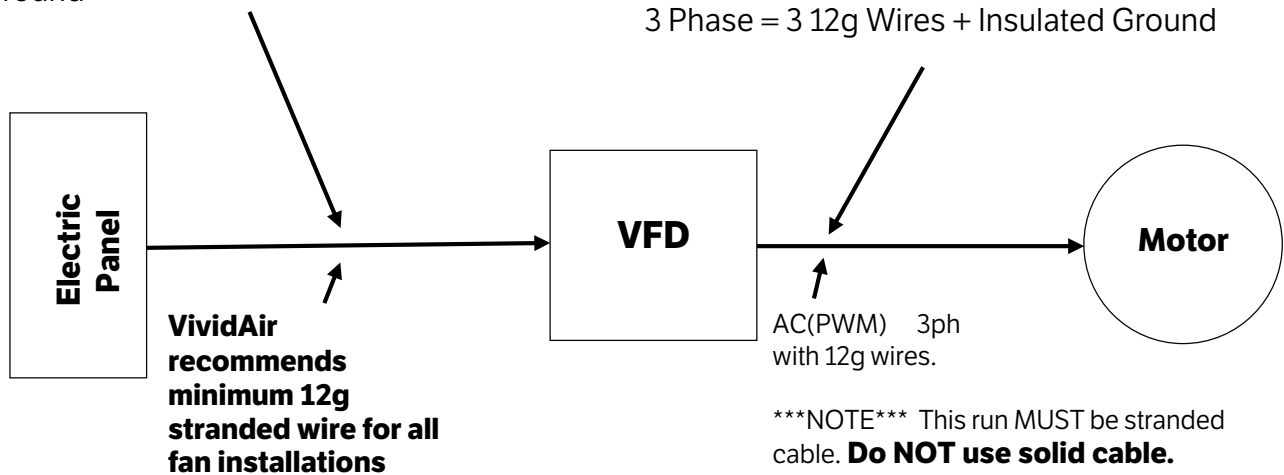

10. Maximum Cable Length

Cable Length Between the VFD and Motor			
Normal Length	No Additional Device Required or Change in VFD HP		
	230 VAC	Max 200 ft	No HP Change
	460 VAC	Max 200 ft	No HP Change

If lengths beyond 200' are required the best practice is to order the optional "Remote Mount Keypad Kit". Contact your salesperson or local VividAir representative for more information.

For installations with cable lengths exceeding a 200' run from the VFD to the Motor please consult the factory at: 1-844-GOFANME (463-2663).

11. Power Requirements

7ft TAZ Fans

GFY-TAZ-72-480 (7ft fan powered by 460/480V 3 phase) = 4.1 amps

GFY-TAZ-72-240 (7ft fan powered by 208V or 230/240V 3 phase) = 8.2 amps

12. Wire Location

- DO NOT RUN input and output power cables in the same conduit.
- DO NOT RUN control cables with any power cables in the same conduit.
- DO NOT RUN different fan output power cables in the same conduit.
- You can run different fans input power cables in the same conduit.

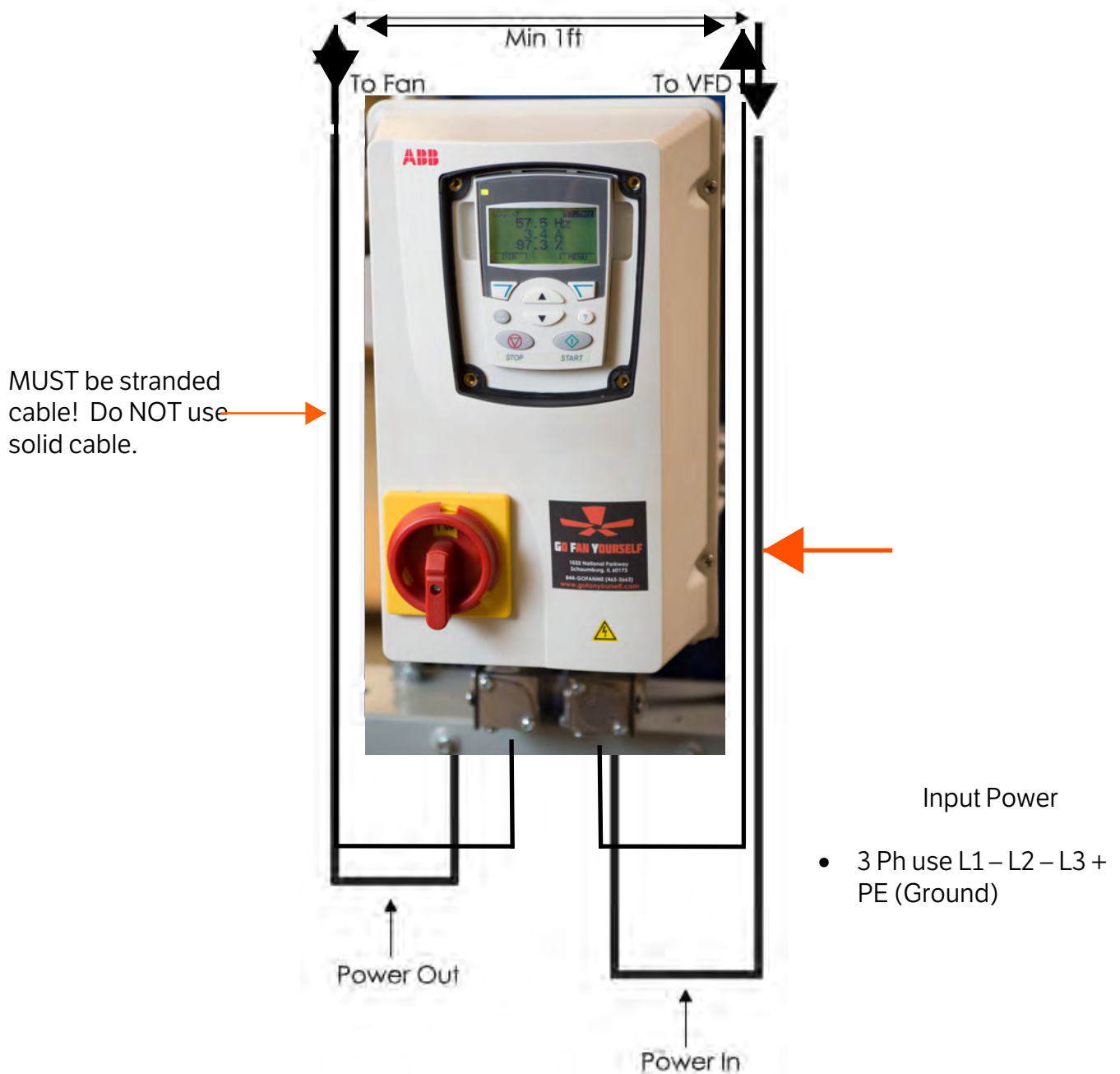

ESFR Fire Relay Connection for VividAir Controller

Remove the jumper from pins 4 & 5 and connect the fire alarm relay as shown.

**+ 24VDC To Fire Relay
Input From Pin 1**

**N.C. Output From Fire
Relay To Pin 4**

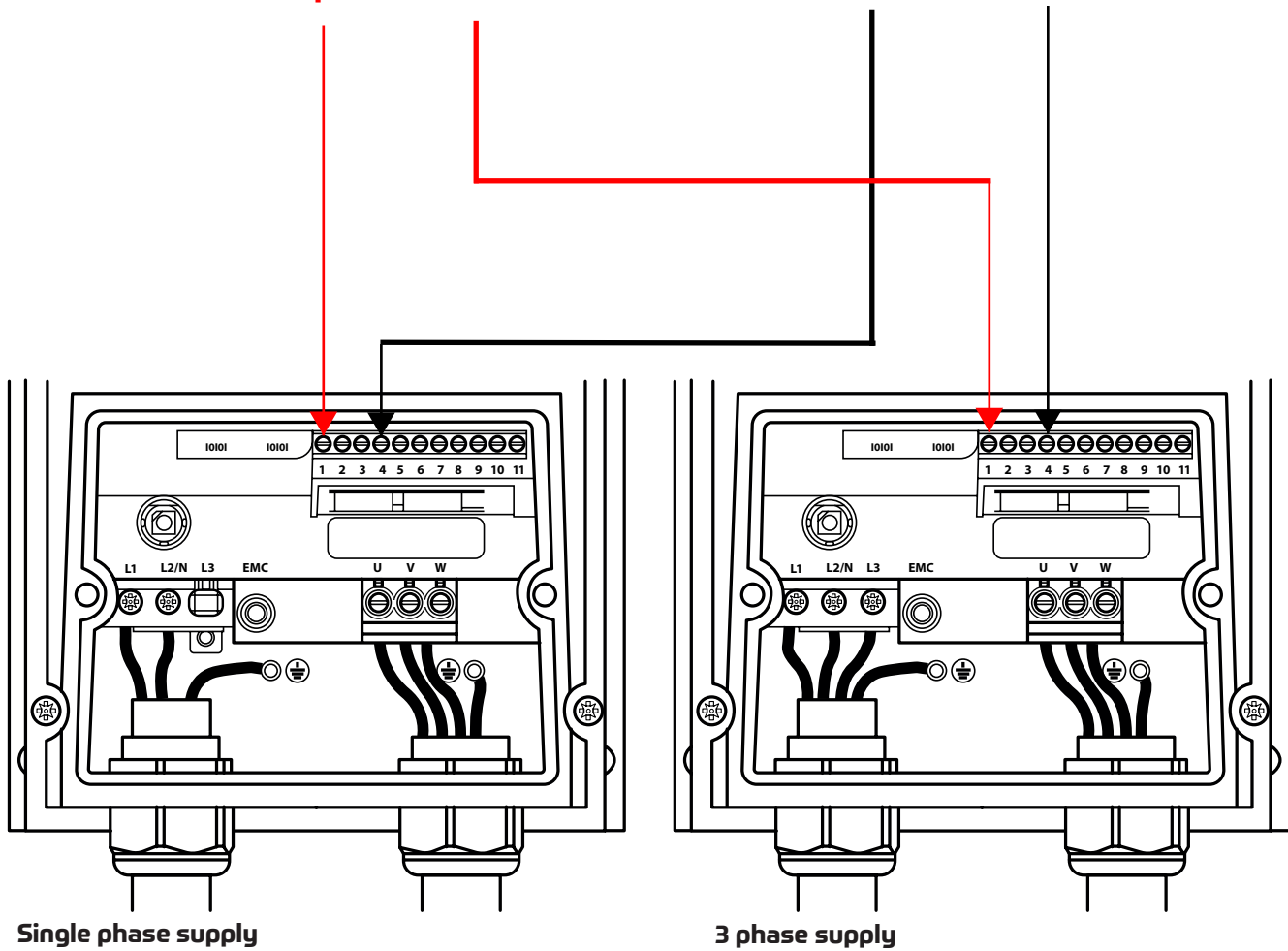

Power Wiring Shown For Reference

VividAir Connection For ESFR Suppression System

ACS355 Controller - 200-240VAC & 380-480VAC 3 Phase Applications Only

- 1) Primary Method - The Control is designed to take a PNP (Sourced) +24 VDC signal from an ESFR fire suppression system. The ESFR system will supply the +24V DC power.
 - o Digital Input "DI3" (POS.14) = +24V signal wire.
 - o DCOM (POS.11) = 0V common signal wire.
 - o The Drive will go in to an alarm condition when the +24VDC signal is lost. Fan operation is prevented and the Control will stay in the alarm condition until the +24VDC signal is restored.

- 2) Alternate Solution - Run the output from Pin 9 (+24VDC) to a relay and run the output from the relay to Pin 14 (Digital Input 3 "DI3"). Control the relay with the ESFR fire suppression system.

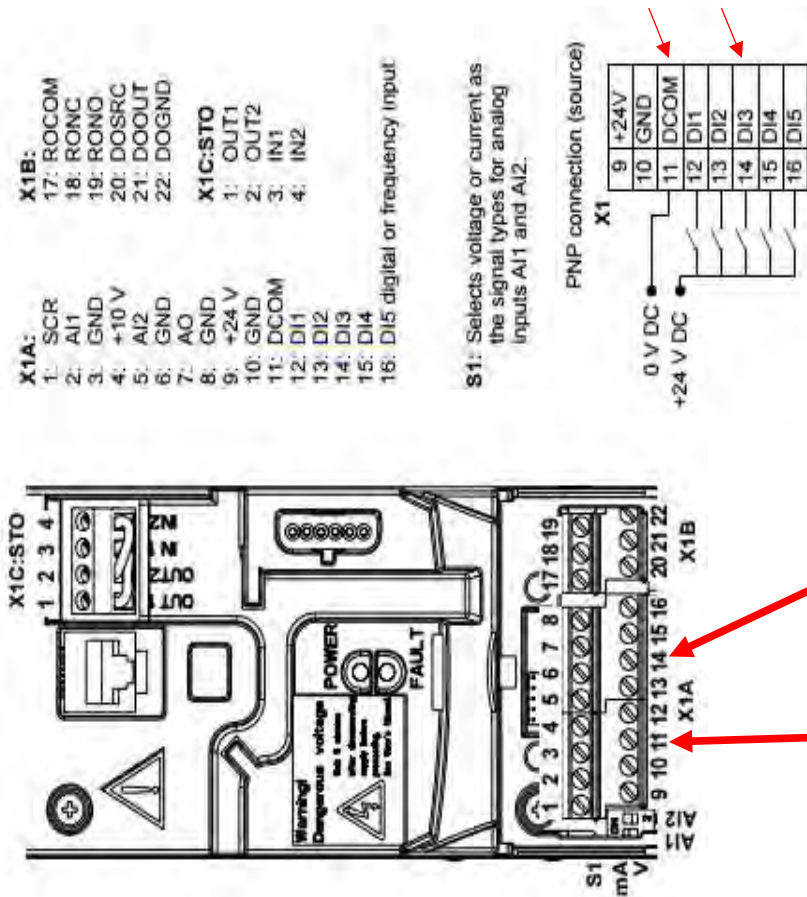

+24 VDC ESFR Digital Input

0 VDC DCOM From ESFR Circuit

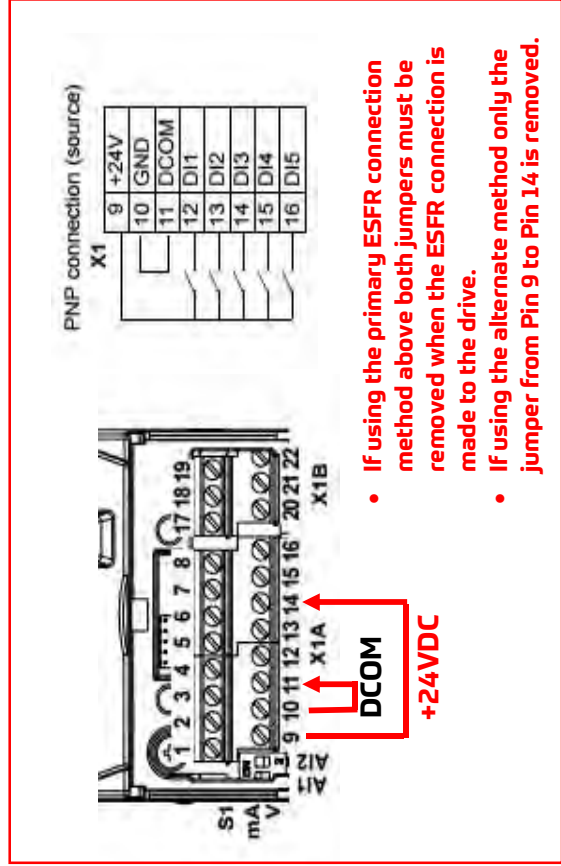

VividAir Connection For ESRF Suppression System

ACS255 Controller - 100-120VAC & 200-240VAC Single Phase Applications

This diagram is designed to take a PNP (Sourced) +24 VDC signal from an ESRF fire suppression system. The ESRF system will supply the +24 VDC power.

Run the +24 VDC signal wire to terminal 4 and route 0V COM to terminal 7. There should be room in the terminal block to accept both wires on terminal 7.

To enable the ESRF signal input see the programming steps below. The drive will go into a fault condition once the 24VDC signal is lost and will not allow fan operation until that signal is restored.

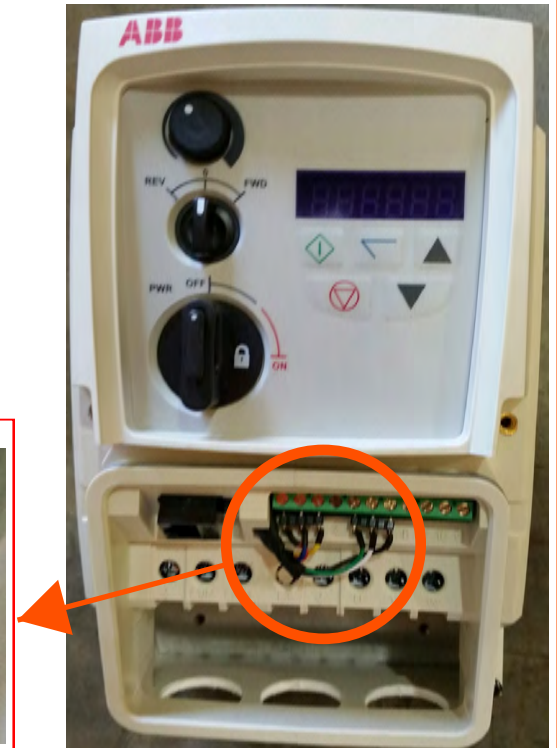
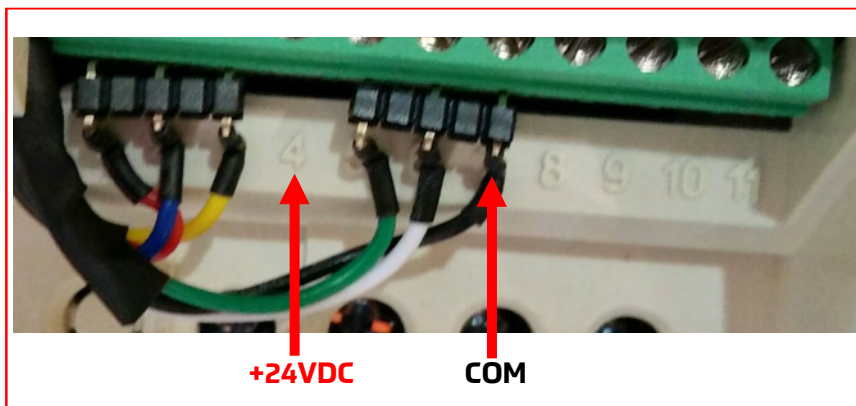

Programming Instructions for ABB ACS255 Controller - Enable ESRF Input

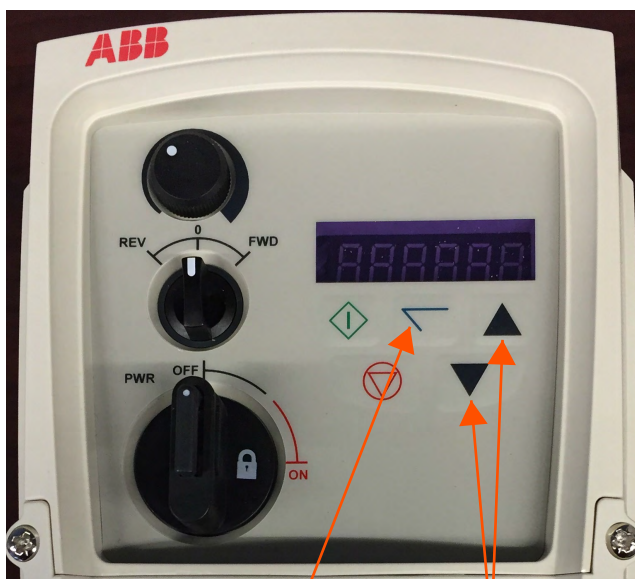

Enter/Select Up/Down
Arrows

- 1) Once ESRF connection is complete from fire suppression system. Power up the drive.
 - a) Display should say "SToP".
- 2) Hold "Enter/Select" for 1 second.
 - a) Drive will enter programming mode.
 - b) PAR S (parameter short list) should be displayed.
 - c) Press "Enter/Select".
 - d) Display should show 4 digits (they may be "0000").
- 3) Use Up/Down Arrow Keys and locate parameter 9902.
 - a) Press "Enter/Select" to select.
- 4) Use Up/Down Arrow Keys to change parameter 9902 setting to "6".
 - a) Press "Enter/Select" to save.
 - b) Display should return to parameter 9902.
- 5) Press and hold "Enter/Select" until display reads "StoP". You have exited programming mode.
- 6) Drive will immediately fault if ESRF signal is missing.

14. Wire Connections (Motor)

Always wire the motor per the wiring diagram on the inside of the motor cover plate.

All single phase applications MUST be wired as "Low Voltage".

Voltage Supply to the VividAir or ABB VFD Controller:

380-480VAC 3 Phase

Jumper for "High Voltage"

Voltage Supply to the VividAir or ABB VFD Controller:

**200-240VAC 3 Phase
200-240VAC 1 Phase**

Jumper for "Low Voltage"

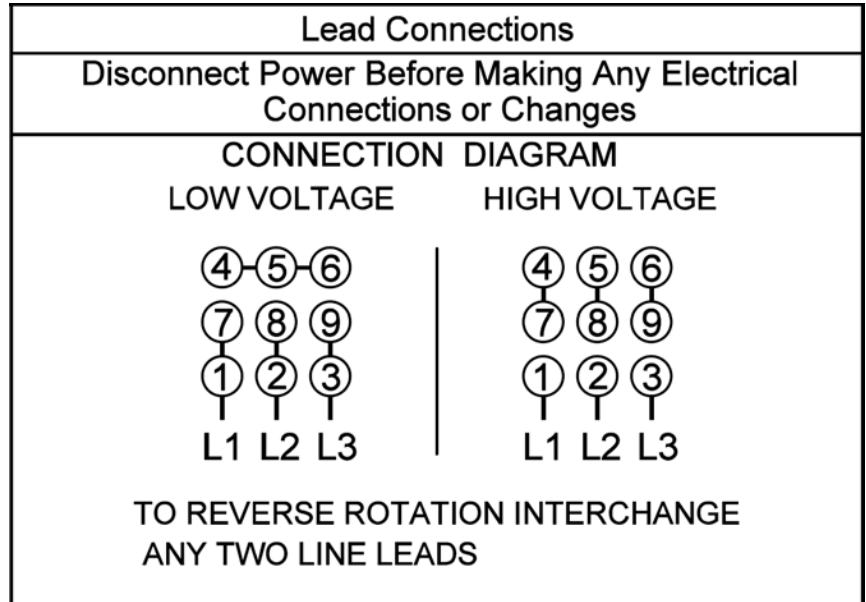

Be sure to wire all single phase applications as 200-240VAC three phase applications. The controller changes the single phase signal it receives from the panel to 200-240VAC 3 phase.

Low Voltage Wiring

- T1 to T7 and L1 (incoming 208-240 VAC)
- T2 to T8 and L2 (incoming 208-240 VAC)
- T3 to T9 and L3 (incoming 208-240 VAC)
- T4 to T5 and T6 (tie together or mount to a single post)
- T5 to T4 and T6 (tie together or mount to a single post)
- T6 to T4 and T5 (tie together or mount to a single post)
- T7 to T1 and L1 (incoming 208-240 VAC)
- T8 to T2 and L2 (incoming 208-240 VAC)
- T9 to T3 and L3 (incoming 208-240 VAC)

High Voltage Wiring

- T1 to L1 (incoming 480VAC)
- T2 to L2 (incoming 480VAC)
- T3 to L3 (incoming 480VAC)
- T4 to T7
- T5 to T8
- T6 to T9
- T7 to T4
- T8 to T5
- T9 to T6

Quick Operations Instructions for the VividAir VFD Controller



Stop/Select Direction:

Both Buttons Disabled

To Change Speed:

- The display will have an "H", indicating "Hertz". The frequency (or speed) the fan is turning will be indicated numerically. H - 45.8 for example.
- The word "STOP" will be shown any time there is power applied to the drive but the fan is not turned on. STOP indicates the fan is on and ready for use.

15. Quick Operation Instructions for the VFD (it comes fully programmed from VividAir)

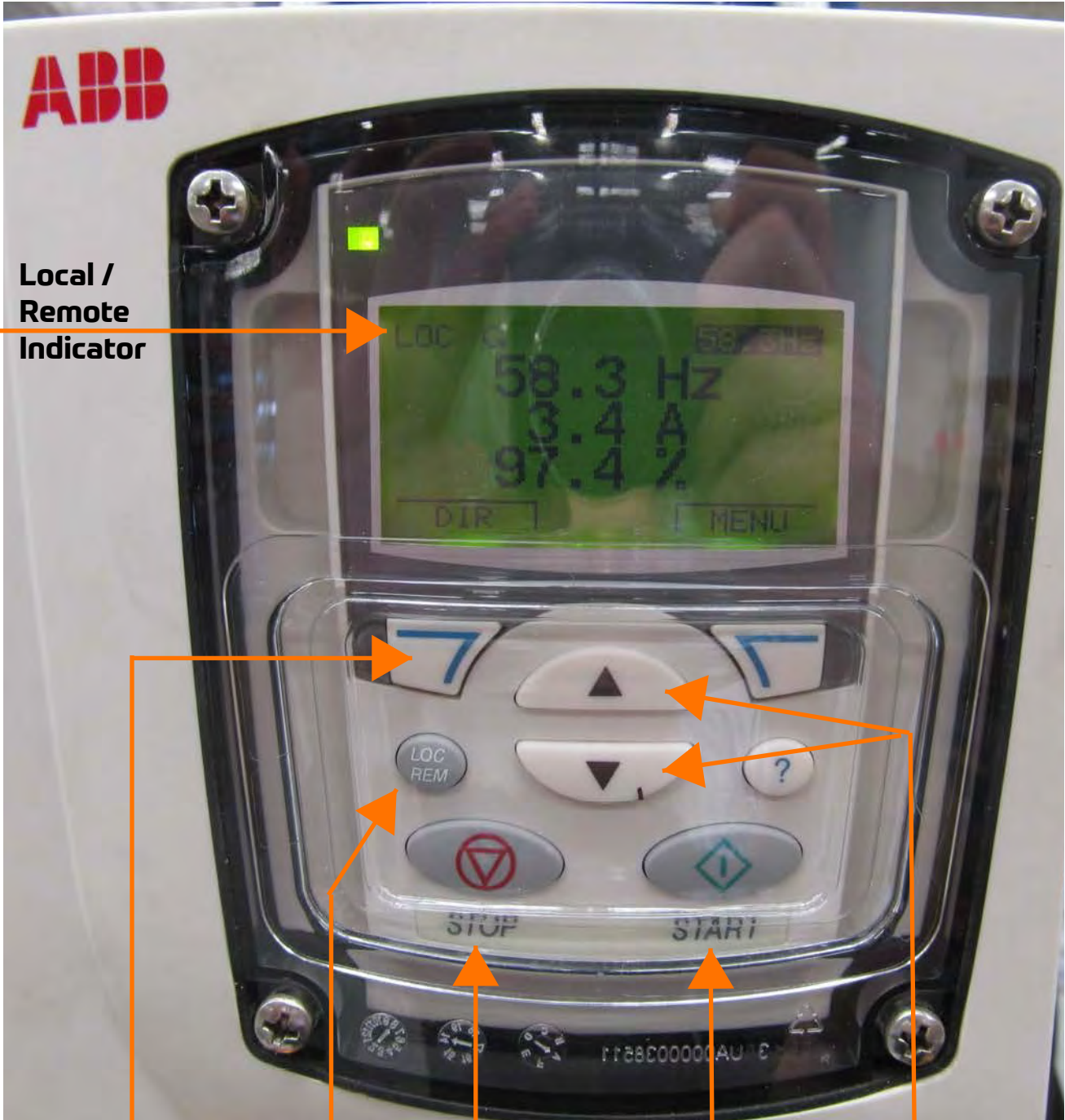

The image shows the ABB VFD control panel with a digital display and several control buttons. The display shows 'LOC' in the top left corner, '58.3 Hz', '3.4 A', and '97.4 %'. Below the display are buttons for 'DIR' and 'MENU'. The control panel features a '7' button, a 'LOC REM' button, a red stop button, a green start button, and a '?' button. There are also up and down arrow buttons. At the bottom, there are 'STOP' and 'START' buttons. Orange arrows point from text labels to these buttons. A green indicator light is visible at the top left of the panel.

Local / Remote Indicator

To Change Direction:

To Stop:

To Start:

To Change Speed:

Local / Remote - Must be in "Local" for the controller to operate the fan.
Look for "LOC" or "REM" if the upper left hand corner of the display.

Quick Operations Instructions for the VFD Controller ACS255 ABB Control

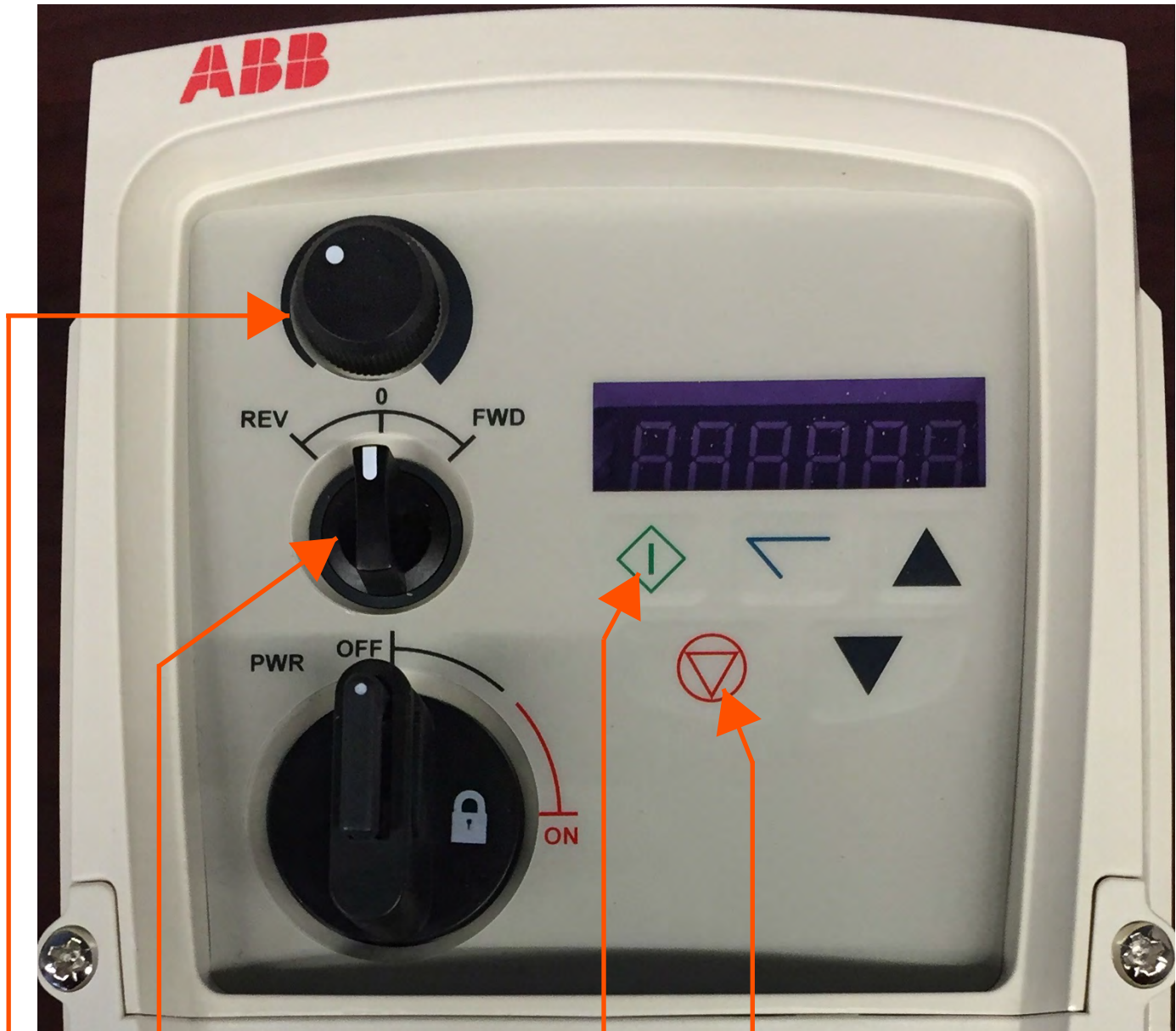

Stop/Select Direction:

Both Buttons Disabled

To Change Speed:

- The display will have an "H", indicating "Hertz". The frequency (or speed) the fan is turning will be indicated numerically. H - 45.8 for example.
- The word "StoP" will be shown any time there is power applied to the drive but the fan is not turned on. StoP indicates the fan is on and ready for use.

16. Recommended Maintenance Schedule

1. No maintenance shall be done on the fan or mount or while it is in operation or powered.
2. No maintenance shall be done on the fan controller while powered unless the task involves reprogramming or troubleshooting the electrical system.
3. The fan controller shall be locked out while maintenance is ongoing on the fan or mount.
4. All personnel working on the fan or mount, shall wear the appropriate personal safety equipment as mandated by local, provincial, and national regulations.
5. A risk assessment shall be performed before any work is done. A checklist shall be completed and shall include any emergency contacts for the area.

CAUTION: Build-up on the TAZ high-velocity fan blades (dust / grime / dirt / debris) will have potential cause and effect. This could impede the fan's overall speed, this can cause the fan blades to wobble and get out of balance, which can put a strain on the fan's motor. Can potentially cause the blades to impact the fan housing and become undone from the entire fan assembly due to being out of balance. In addition, dust/grime could also build up on the motor/belts/pulley, which could be potentially a safety issue. The fan blades/drive train/housing should be cleaned periodically for maximum performance and safety. By avoiding the recommended manufacturer's guidelines and periodic maintenance the warranty is void.

Power Unit

Motor

Our motor or gear motor manufacturers supply VividAir with motors/gearmotors built for our application. Designed for use with variable frequency drives; they are wound with 392° (200°C) moisture resistant Inverter Spike Resistant (ISR) magnetic wire which dramatically extends the life of the motor compared to motors with non-ISR wire. They have a three year limited warranty.

Maintenance Schedule

Initial Six Months

- Check for hot spots
- Check all electrical connections and tighten if necessary.

Repeat Every 12 Months Thereafter

Belt/Tensioner

TAZ Fans are belt driven with an auto-tensioner. Check both belts for uneven wear or cracking every 12 months. The drive/tensioning assembly has a three year limited warranty.

Blade

The blade is designed for maximum efficiency and quietness with maximum air disruption directly below the fan. The blade has a 3-Year warranty.

Maintenance Schedule

After 12 Months

- The blade rotates on a sealed bearing assembly that should never need maintenance. Check the seal at each end for signs of leakage.
- Ensure blade is intact.
- Check fan level and clean as required.

Repeat Every Twelve Months Thereafter

Mounting

The standard mounting system is (4) lengths of chain suspending the fan from each of the (4) corners. Steel cable is also an option to hang the fan.

Maintenance Schedule

Initial Six Months

- Verify all hardware connections.
- Verify fan level.

Every 12 Months Thereafter

NOTE: Maintenance schedule is based on running 5,000 hrs/year and is a guideline to ensure safe and continuous operation of the fan(s). In cases of extreme operation (e.g. high humidity, aggressive environment, or large temperature variations), shorter intervals between service is recommended.

Motor Pulley Adjustment or Removal

1. Use a 5mm hex wrench to remove both bearing shaft pulley anchor set screws.
2. Inset one of the set screws into the Jack Screw hole and slowly tighten.
 - a. Tightening the jack screw location will loosen the pulley from the fan bearing shaft allowing adjustment for proper belt alignment or removal for service.
3. Tighten the set screw in the jack screw location while tapping on the pulley with a block of wood. Once the pulley begins to move stop tightening the set screw and adjust or remove the pulley.
4. Reverse this process to assemble the pulley on the motor shaft.
5. Be sure the bearing shaft pulley is in perfect alignment with the motor pulley by using a straight edge.
6. Belt tension should be snug without the tensioner pulley in place. Once the tensioner pulley is in place it should deflect the belt only a slight amount.

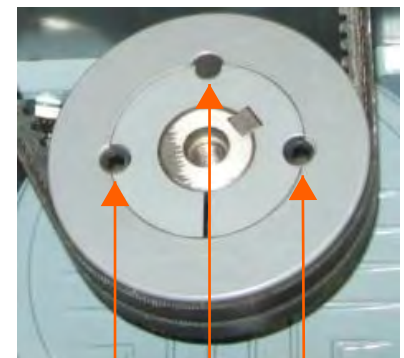

Set Screw

Set Screw

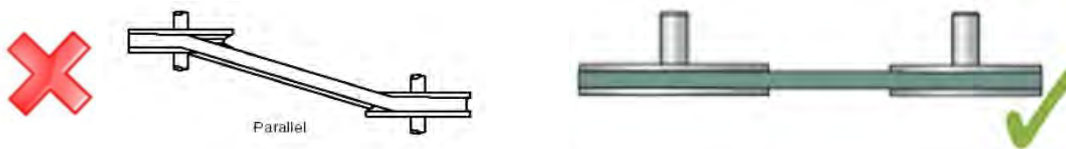
Jack
Screw

Safety Precautions

1. Hanging chain (or cables) installed as per page 6 in this fan installation manual.
2. Louvers installed as per pages 8 & 9 in this fan installation manual.
3. See next page for required clearances.
4. If installed in storage facility between racks, signs must be installed identifying fan locations.
5. The motor has thermal protection in case of overheating.
6. The ABB variable frequency drive has several safety features such as current limit, motor overload, minimum, maximum and ramp speed control. The controller also features a LOTO disconnect all housed within a NEMA 4X enclosure.

17. 7 FT TAZ Fan Clearance Requirements

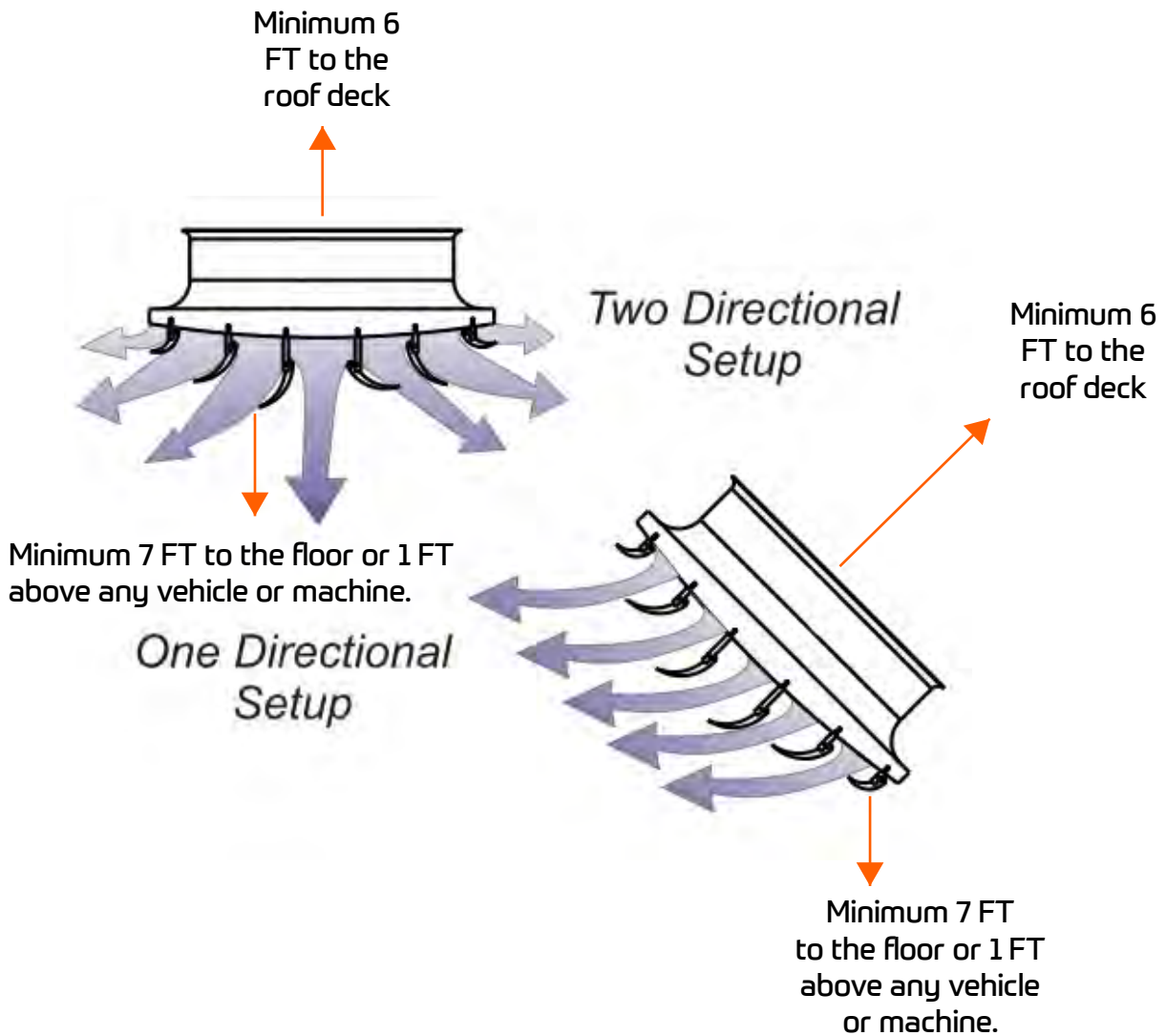

Clearances

- Min 6 FT center of fan to roof deck for ideal operating performance
- Min 7 FT floor to the lowest hanging point on the TAZ fan.
 - VividAir recommends that the fan be hung with a minimum of 1FT clearance for any movable vehicle or machine that operates within the facility.

Contractor is responsible for verifying all site conditions to include field dimensions where applicable. If the contractor elects to make any changes without notifying VividAir the contractor is responsible for the same. All drawings are to be used as general architectural intent unless otherwise stamped. See Engineer drawings for structural design information. Contractor to ensure that all building departments and authorities are informed in regard to the work and that all permits are attained before commencing work.

18. VividAir Recommended Maintenance Checklist

Fan Location:
Fan Diameter:
Motor Serial Number:
Motor Size:

Fan Location:
Fan Diameter:
Motor Serial Number:
Motor Size:

Fan Location:
Fan Diameter:
Motor Serial Number:
Motor Size:

Fan Location:
Fan Diameter:
Motor Serial Number:
Motor Size:

Fan Location:
Fan Diameter:
Motor Serial Number:
Motor Size:

Fan Location:
Fan Diameter:
Motor Serial Number:
Motor Size:

Date	Mechanic Signature

Date	Mechanic Signature

Date	Mechanic Signature

Date	Mechanic Signature

Date	Mechanic Signature

Date	Mechanic Signature

Date	Mechanic Signature

Date	Mechanic Signature

Date	Mechanic Signature

Date	Mechanic Signature

Date	Mechanic Signature

Date	Mechanic Signature

Date	Mechanic Signature

Date	Mechanic Signature

Date	Mechanic Signature

Date	Mechanic Signature

Date	Mechanic Signature

Date	Mechanic Signature

Date	Mechanic Signature

Date	Mechanic Signature

Date	Mechanic Signature

Date	Mechanic Signature

Date	Mechanic Signature

Date	Mechanic Signature

Limitation of Warranties and Liabilities

Three Year Limited Warranty

VividAir TAZ Fans are of industrial grade construction and should provide many years of service provided routine maintenance is completed as scheduled. Warranty duration is as follows:

a) Blades	3 Year Warranty
b) Fan Body	5 Year Warranty
c) Motor	3 year Limited Warranty
d) Gear Reducer	3 year Limited Warranty
e) VFD Control Panel	3 year Limited Warranty
f) Labor	1 year Limited Warranty (pre-approved)

Go Fan Yourself[®] warrants that this product will, under normal use and service as specified by Go Fan Yourself[®], operate properly and be free of defects in materials and workmanship for a period of three years from the date of purchase by customer. The term “operate properly” in this context applies to mechanical, electrical and structural functions only. No guarantee, unless and except by separate written agreement, is made regarding dimensions of air movement generated or the effectiveness of this product for its intended purpose.

Labor warranty will cover all reasonable costs paid by the customer to an independent contractor (including dealers) to remove, dismantle, reassemble or reinstall any of the warranted Products during the first year that the Product is in service. All receipts are to be submitted to Go Fan Yourself[®] which will be paid upon completion of the installation of the Product and after the return of the failed unit. Go Fan Yourself[®] will only issue a credit/check to the customer/dealer and will not be held responsible for paying the independent contractor.

Warranty Exclusions

Please note that the following may or could void any or all of the above listed warranties.

- Not following required installation procedures as in installation guide and all other documentation supplied with the fans and related equipment supplied by manufacturers of individual fan and control components.
- Not following all relevant codes and ordinances, not limited to National Electrical Code, provincial, or state and local building codes.
- Not following electrical engineering industry standards regarding approved method of installing solid-state electrical equipment having characteristics of fans and all components included in this product. Any modification to installation, product, controls without written authorization from Go Fan Yourself[®], even if attempting to diagnose and/or repair a problem.
- Misuse, abuse, accidents, unreasonable use, or Acts of God.
- Incorrect electrical current, voltage or supply.
- Running fans at higher than recommended speeds.
- Re-setting parameters of any control without prior approval from Go Fan Yourself[®].
- Failure to use all installation and mounting hardware supplied by Go Fan Yourself[®].
- Failure to perform periodic maintenance as detailed in the TAZ Fan Installation Manual.

Limitation of Warranties and Liabilities

Three Year Limited Warranty

Go Fan Yourself® reserves the right to make the final determination, based on its own evaluation of the components as to whether:

- The problem in question is the result of a defect in design, workmanship or materials and not the result of error, misuse or abuse on the part of the customer as stated above.
- Whether the problem or defect is material and requires action under this warranty.
- Whether the remedy of repair or replacement is appropriate.

Go Fan Yourself® will not be responsible for remedial work necessary to correct installation procedures that do not conform to those established by the instructions, codes and standards, regardless of when the installation occurred.

With regard to electrical and electronic components provided by Go Fan Yourself® that comprise part of the products, including motors, motor drives and variable frequency drives, Go Fan Yourself® relies on the determination by the original manufacturer as to whether the failure of such components was the result of a defect. If the manufacturer of such components determines that there was no defect and therefore refuses to cover it under warranty, Go Fan Yourself® likewise will not warranty such item unless Go Fan Yourself® determines that the failure of such electrical or electronic component was the result of a defect of design, workmanship or material within some other part of the products.

Warranty Duration

With respect to replacement or repair rendered, Go Fan Yourself® warrants that the parts replaced or repaired will operate properly and be free from defects in materials and workmanship for a period of 90 days from the shipment date of the replacement products to the customer or for the remainder of the original warranty period, whichever is longer.

Warranty Claim Instructions

1. Contact your original dealer/salesman of the purchase when you first notice problem with the product.
2. It will be the responsibility of the dealer or salesman to assist the customer in determining what product is causing the problem.
3. If they cannot diagnose the problem, they are to contact Go Fan Yourself® with all the necessary information (See VividAir RMA Form).
4. The appropriate department will then be in contact with the customer to determine the cause of the problem.
5. Once diagnosed, submit a Purchase Order for a replacement unit complete with price.
6. A replacement unit will be shipped out upon receipt of the PO. This PO allows for an order to be established in the Go Fan Yourself® system.
7. Once the units have been changed over, submit all reasonable costs to Go Fan Yourself® for payment.
8. No credits or checks will be issued until all original products are received back at Go Fan Yourself® unless Go Fan Yourself® directs otherwise.

Limitation of Warranties and Liabilities

WARRANTOR: The warrantor for the limited warranties set forth herein is Go Fan Yourself® (“Company”)

LIMITED WARRANTY: This limited warranty (this “Warranty”) applies only to the original End-User (the “End-User”) of any Go Fan Yourself® TAZ Fan(s) (Individually and collectively, the “Product”) and cannot be transferred. This Warranty applies even in the event that the Product is initially sold by Company for resale to End-User.

WHAT THIS WARRANTY COVERS: The Product is covered by a Lifetime Warranty on blades and body with a standard Three-Year Limited Warranty covering all other components, when used in accordance with the operation and maintenance procedures prescribed in the Go Fan Yourself® Installation Manuals.

If Company finds, in its sole discretion, that any Product fails within the Three-Year Warranty Period, Company will, as its sole obligation and the End-User’s sole remedy for Company’s breach of this Warranty, repair or replace the Product, at its option, F.O.B. Company’s factory.

WHAT THIS WARRANTY DOES NOT COVER

-any defects or damages caused by:

- (a) failure to properly store the Product before installation;
- (b) shipping and delivery of the Product if shipping is FOB Factory;
- (c) neglect, accident, abuse, misuse, misapplication, or incorrect installation;
- (d) repair or alteration not authorized in writing by Go Fan Yourself® personnel;
- (e) improper testing, operation, maintenance, adjustment, or modification of any kind not authorized in writing by Go Fan Yourself® personnel;

OR

- (f) use the Product under other than normal operating conditions or in a manner inconsistent with the product’s label or instructions.
 - controls and/or any other external electronic controlling devices.
 - exclusions listed in the standard Three-Year Limited Warranty.
 - any products or components purchased prior to effective date of this Warranty.

Limitation of Warranties and Liabilities

This warranty is not valid

- (a) if the Product's serial numbers have been removed or are illegible; OR
- (b) if any warranted items repaired or replaced pursuant to this Warranty will be warranted for the remaining portion of the original Warranty subject to all the terms thereof. Company shall not be responsible for any charges for testing, checking, removal or installation of warranted items unless authorized in writing by Company personnel; OR
- (c) if failed to submit records at time of performing Recommended Maintenance Schedule as prescribed in the Go Fan Yourself® Installation Manuals.

LIMITATION OF LIABILITY: The remedies of the End-User set forth herein are exclusive and are the sole remedies for any failure of Company to comply with its obligations hereunder. In no event shall Company be liable in contract, in tort (including negligence or strict liability) or otherwise for damage to property or equipment other than the Products, including loss of profits or revenue, loss of use of Products, cost of capital, claims of customers of the End-User or any special, indirect, incidental or consequential damages whatsoever. The total cumulative liability of Company hereunder whether the claims are based in contract (including indemnity), in tort (including negligence or strict liability) or otherwise, shall not exceed the price of the Product on which such liability is based. Company shall not be responsible for failure to provide service parts due to causes beyond Company's reasonable control. "Lifetime" is defined as a period ending one (1) year after Go Fan Yourself® discontinues manufacturing the product, as such period is defined by Go Fan Yourself®, but in no event shall this period be less than one (1) year from the date that the Warranty Period commences.

END-USER'S OBLIGATIONS: In order to receive the benefits of this Warranty, the End-User must use the Product in a normal way; follow the Product's Installation Manuals; and protect against further damage to the Product if there is a covered defect. Submit records at time of performing Recommended Maintenance Schedule as prescribed in the Go Fan Yourself® Installation Manuals.

OTHER LIMITATIONS: Company's obligations under this Warranty are expressly conditioned upon receipt by Company of all payments due to it, including all applicable interest charges. During such time as Company has not received payment of any amount due to it for the Product, in accordance with the contract terms under which the Product is sold, Company shall have no obligation under this Warranty. Also during such time, the period of this Warranty shall continue to run and the expiration of this Warranty shall not be extended upon payment of any overdue or unpaid amounts.

COSTS NOT RELATED TO WARRANTY: The End-User shall be invoiced for, and shall pay for, all services not expressly provided for by the terms of Warranty, including without limitation, site calls involving an inspection that determines no corrective maintenance is required. Any costs for replacement equipment, installation, materials, freight charges, travel expenses or labor of Company representatives outside the terms of this Warranty will be borne by the End-User.

OBTAIN WARRANTY SERVICE: Call Go Fan Yourself,® Service 1-844 GOFANME (463-2663). Company will not accept any product for return, credit or exchange unless expressly authorized by Company in writing and delivered FOB Company factory with proper Return Material Authorization form attached to the product.

Any and all parts of this guide are subject to change without notification.